

Ma dareemeysaa welwel ku aaddan in canuggaaga dhawr iyo toban jirka ahi uu isticmaalyo sigaar iyo tubaako iyo nikotin?

Xirmadan qoraalka ahi waxay ku saabsantahay tubaakada iyo nikotiinka, waxayna ulajeeddadeedu tahay in ay ku siiso taageero ku aaddan sida aad u caawin kartid canuggaaga dhawr iyo toban jirka ah.

Qiiqa sigaarka waxaa ku jira in ka badan 4000 oo maaddo oo waxyeello leh oo afartameeye ka mid ahi ay kansar keeni karaan. Xitaa sigaar cabidda dadban iyo xaflad- ama fasax sigaar cabiddu waxay kordhinayaan halista cudurrada sambabbada, wadnaha iyo xididdada dhiigga. Carruurto waxay sigaarka ka qaadi karaan infekshinno iyo neef, taas oo sidoo kale kordhinaysa khatarta dhimashada caananuugga.

Waxyeellada tubaaku jirka ula mid maaha tan sigaarka, laakiin saas oo ay tahay khatar waa ay leedahay tubaakadu. Tubaakada waxaa ku jira maadooyin kansar keena, in aad tubaako loo cunana waxay xitaa kordhineysaa khatar ta kaadi macaanka nooca 2. Tubaakadu waxay dhaawacdaa xuub axaleedka afka, waxayna badanaa keentaa in uu ciridku dhaawacmo. Nikotiinka waxaa loo gudbin karaa uur ku jirka, dhaawac ayuuna u yahay uur ku jirka.

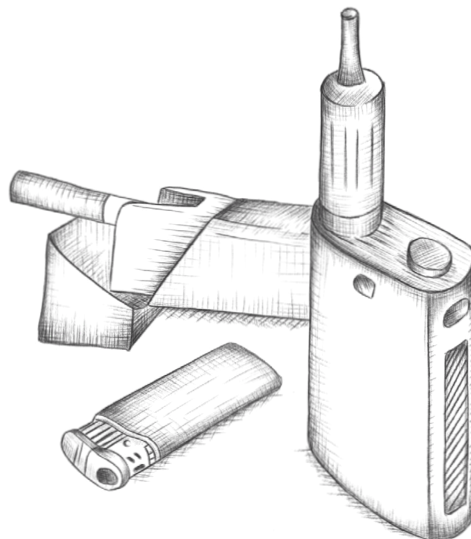

Xaqqiyooyin

- Nikotiin la qabatimo ayaa laga helaa tubaakada iyo waxyaabaha nikotiinka sida sigaarka iyo tubaakada, laakiin sidoo kale waxaa laga heli karaa e-sigaarka iyo shiishadda.
- Shiishadda waxaa lagu cabaa sigaar dhadhan loo yeelay ama qaac fara badan oo ku xiran dabbaska sokorta oo lagu daray waxyaabo macaan u yeela. Way adkaan kartaa in ay dhalinyaradu ogaadaan waxa ay dhab ahaantii ka kooban tahay. In kasta oo ay carfeeyso, ayna u dhedhemeeyso si ka khafiifsan sigaarka caadiga ah waxaa qaaca ku jirta kaarboon oksaydka koowaad, maaddooyin kansar keena iyo nikotiin. Sida qiiqa sigaarka caadiga ah.
- In la cabo e-sigaarka waxaa loo yaqaan “vejping”. Laakiin qiiqa beddelkiisa wuxuu soo saarayaa uumi niokotiin ka buuxyo oo ay sidoo kale ku jiraan maaddooyinka sunta ah iyo walxo kale. E-sigaarka waxaa badanaa lagu suuq geeyaa in uu ka waxyeello yaryahay sigaarka caadiga ah. Laakiin sida ay qabto WHO, ma jiraan wax caddaynaya in ay taasi sax tahay.
- Tubaakada cad kuma jirto tubaako, ee waxaa ku jira nikotiin laga soo saaray tubaako.
- Laga billaabo 1 Luulyo 2022 waxaa la soo jeediyay in 18 sano ay xitaa xad u ahaato iibsashada walxaha nikotiinka ah ee aysan tubaako ku jirin. Waxaa intaas dheer in nooc walba oo sigaar ah laga mamnuucay beeraha iskoolka, meelaha guud ee ciyaaraha, meelaha dibadda leesugu soo adeego, garoomada dibadda ah, meelaha dhismooyinka laga galo iyo gaadiidka dadweynaha.



Wax ay waanaagsantahay in la ogaado

Waxaa jiri kara faham khaldan oo baahsan oo ka dhex jira dhalinyarada oo ku saabsan inta qof ee si dhab ah u isticmaala sigaarka iyo tubaakada iyo waxyaabaha nikotiinka leh.

Waxay u maleeyaan in dad kaloo badan ay taas sameeyaan, taas oo kordhin karta khatarta in dhalinyaro badan ay tijaabiyaan si ay uga mid noqdaan ama u sameeyaan “sida qof kasta oo kale”. Waagii hore waxay ahayd mid aad u badan in sigaarka la bilaabo. Maalmahan, dhalinyarada badankood ma isticmaalaan sigaar iyo tubaako.

Maxaan sameyn karaa ka waalid ahaan?

Isku day inaad nolol maalmeedka uga hadasho wax kasta oo suurtagal ah. Sidaas ayey dabiici ku noqoneysaa in laga hadlo waxyaabo badan oo adadag, sida khamriga, daroogada ama galmada. Weydii su'aalo, dhagaysana. Xidhiidh dhowi wuxuu leeyahay saameyn difaac ah.

- Xuduud u samey, si cadna ugu muuji waxa aad ka filaneysid.
- Ku kalsoonow dareenkaaga. Haddii aad daremeysid in ay wax khaldanyihiin, waxay u badantahay in ay taasi sax tahay.
- La hadal waalidiinta kale si aad u hesho taageero. Qaar ka mid ah waalidiinta saaxiibbada kale kala heshii xeer wadajir ah.
- Mayadaadu isbeddel weyn ayey keeni kartaa! Xitaa haddii aad adigu sigaar cabto ama tubaako cunto waxaad si cad ugu sheegi kartaa carruurtaada iyo dhallinaradaada in ay ka fogaadaan tubaako iyo sigaarba.
- Hubi in uusan canuggaagu si dadban sigaar u cabin. In la jiido sigaarka dadka kale waxyeello ayey leedahay sidoo kale.

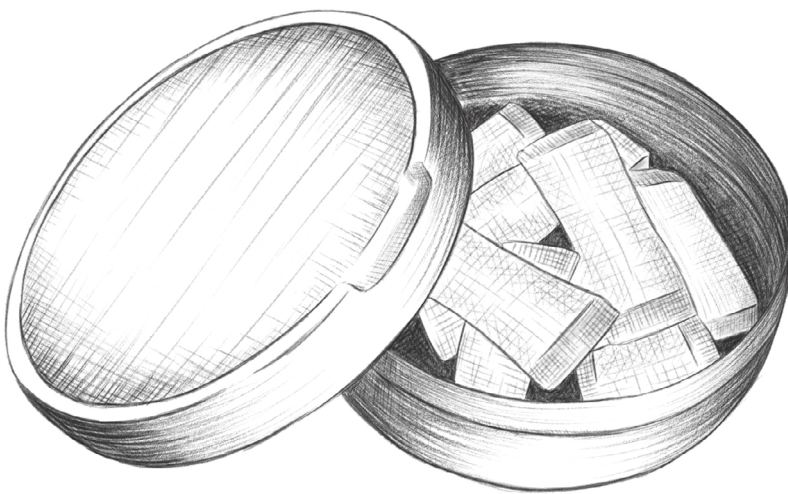

Tira koob

Inta sigaarka ka cabta ardayda dhigata fasalka 9-aad iyo dugsiga sare.

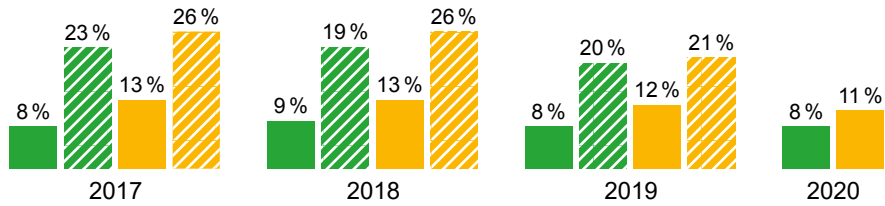

Inta tubaaka ka cunta ardayda dhigata fasalka 9-aad iyo dugsiga sare.

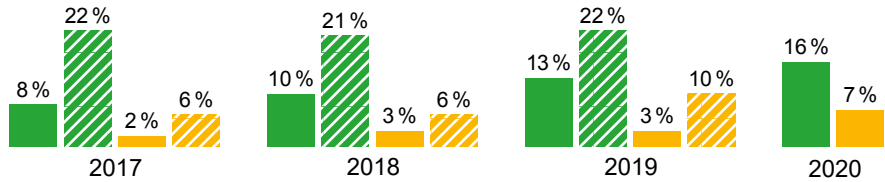

caadooyinka daroogada ardayda iskoolka ', CAN 2020

**Yaad la xiriiri kartaa haddii aad su'aalo qabtid
ama aad rabto caawimo iyo taageero?**

La xidhiidh caafimaadka ardayga ee dugsiga ilmahaaga, xaruntaada caafimaadka ama adeegyada bulshada ee degmada.

Sii akhriso:

Slutarokalinjen.se

Youmo.se